

- 1a** Use a charged and coded OneKEY to deactivate the inVue product that the WS2 stand is plugged into. For Zips Alarm Units, place the OneKEY onto the IR lens and press the button. Then place the magnet key onto the lock icon on alarm unit above the sensor. Push in slightly and unplug the sensor.

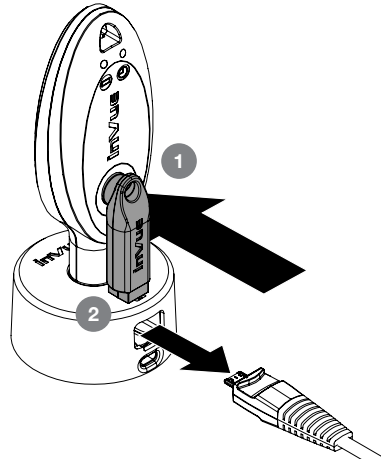

- 1b** If using the S2865 system, place the charged and coded OneKEY onto the Remote IR Dot connected to the system and press the button. Remove the sensor from the S2865 Alarm/Power Box.

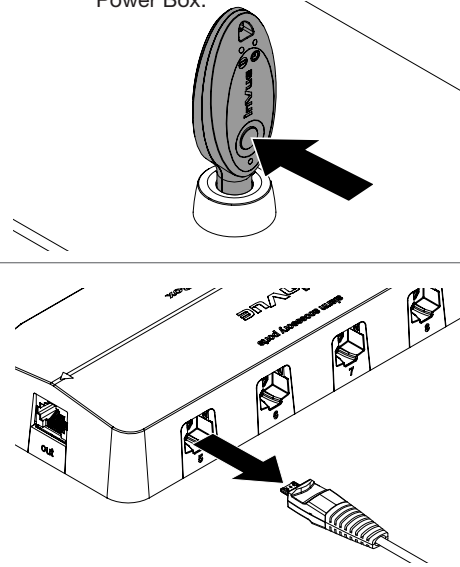

- 2a** If removing the stand from the position, use the scraper removal tool (DNTX93) to break the adhesive bond between the stand and the fixture surface.

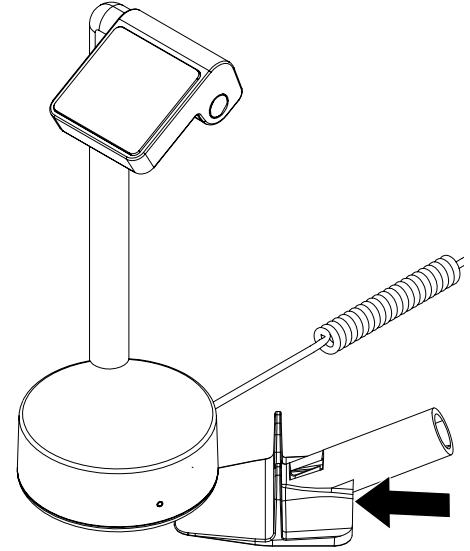

- 2b** If the WS2 stand will be reinstalled, peel the old adhesive from the stand.

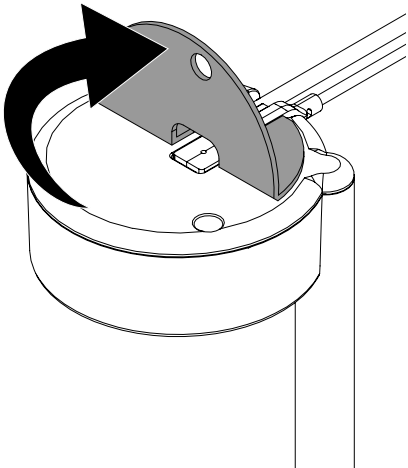

- 2c** If changing out the band clamp cable, remove it at this time.

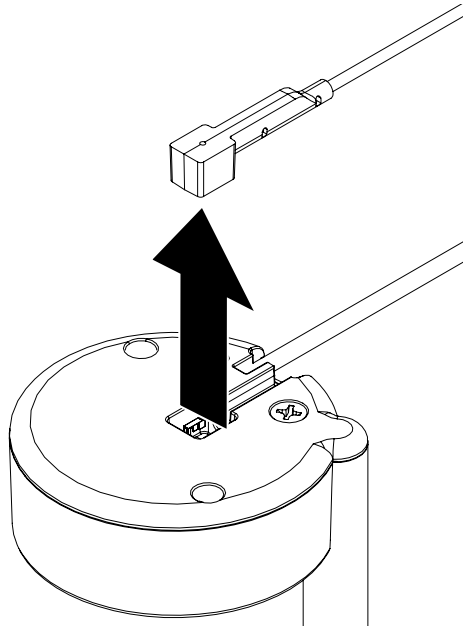

- 2d** Use an alcohol wipe to clean any adhesive residue from the bottom of the stand. Allow it to dry completely.

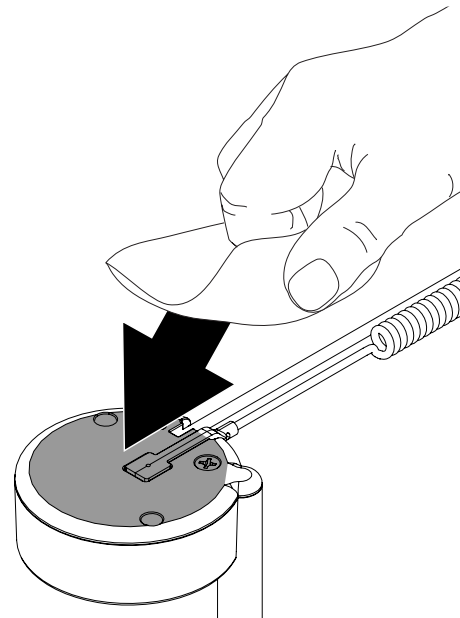

- 2e** Remove one of the replacement adhesives (ADH2321) from its backing and align it with the bottom of the stand. Smooth it into place for at least 10 seconds.
Note: The stand is now ready to be reinstalled. Consult the installation guide for more information.

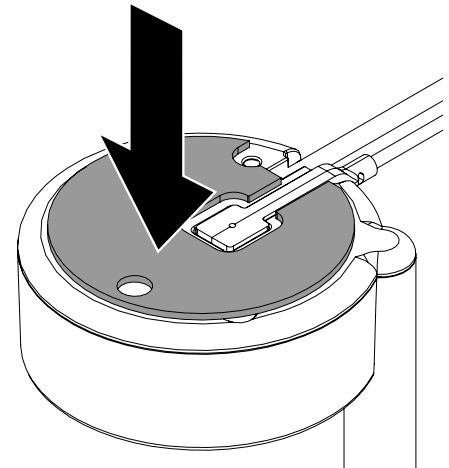

- 3 Use a TT8 bit to loosen the screw in the band clamp. Do NOT attempt to fully remove the screw.

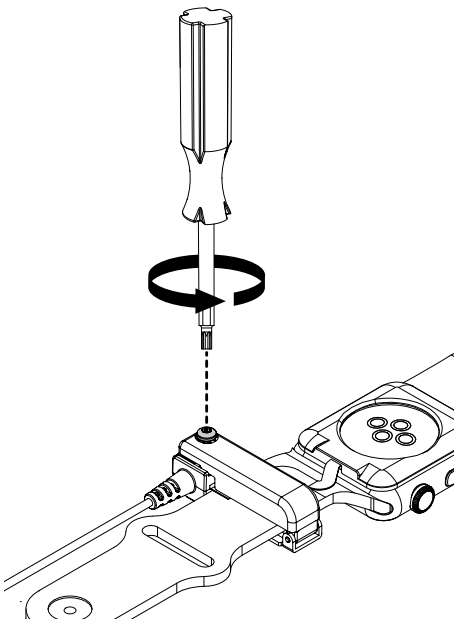

- 4 Lift the band clamp

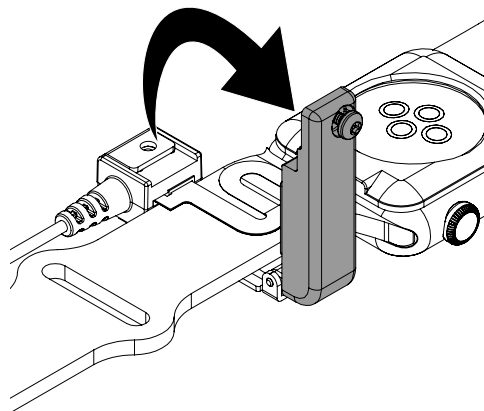

- 5 Unplug the tray or flex sensor from the port inside the band clamp.

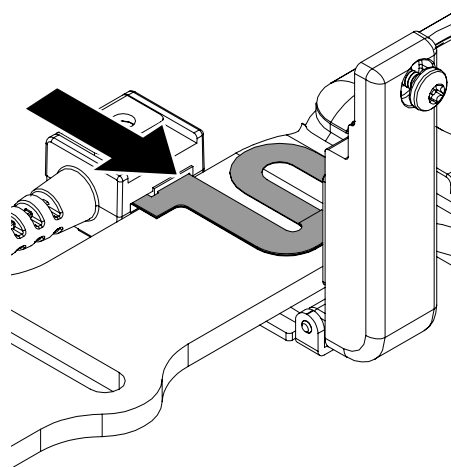

- 6 Remove the tray sensor by carefully prying up one side by hand. Continue lifting the tray sensor from the watch until it is removed.

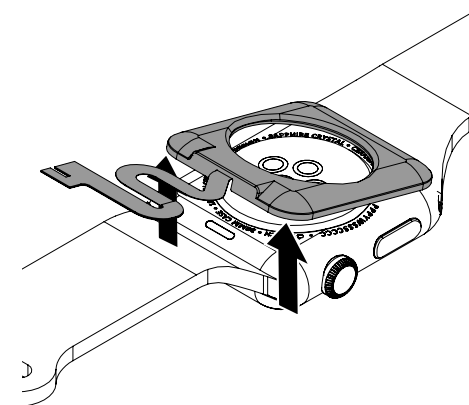

- 7 Use an alcohol wipe to clean any adhesive residue from the bottom of the watch. Allow it to dry completely. **Note:** The watch is now ready to be reinstalled. Consult the installation guide for more information.

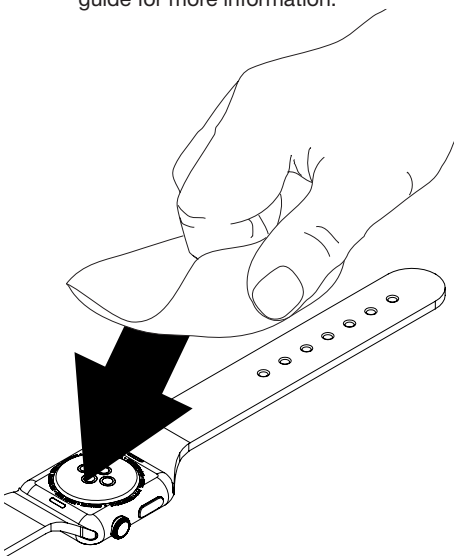

Rev0 08/03/22

invue

www.invue.com

NA / LATAM // 704.752.6513 • 888.55.INVUE

EMEA // +31.23.8900150

APAC // +852.3127.6811

© 2022 InVue Security Products Inc. All rights reserved.
InVue is a registered trademark of InVue Security Products.