

One55 & One65

Angled and Flat Stands and Sensors

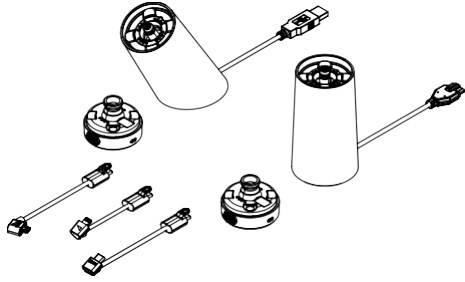

- 1 Stand Installation:**
If routing power cable through fixture, drill a 19mm minimum, 22mm maximum hole in the fixture. **Do NOT mount the stand over a hole larger than 22mm.**

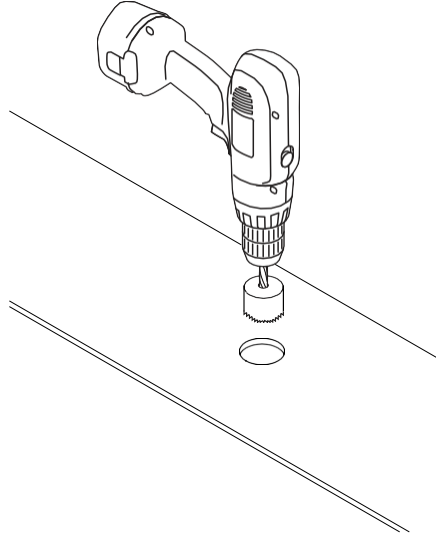

- 2** Wipe fixture with alcohol pad.
Let fixture dry completely.

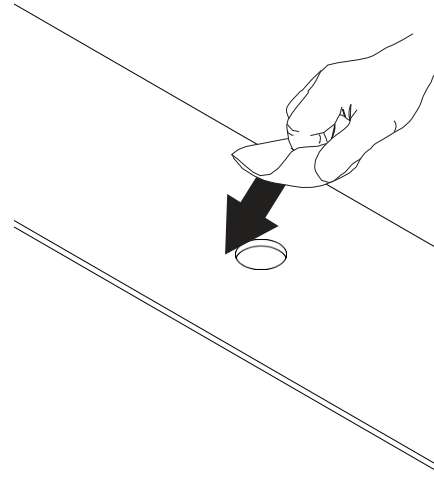

- 3** Determine whether power cable will route through hole or above fixture.

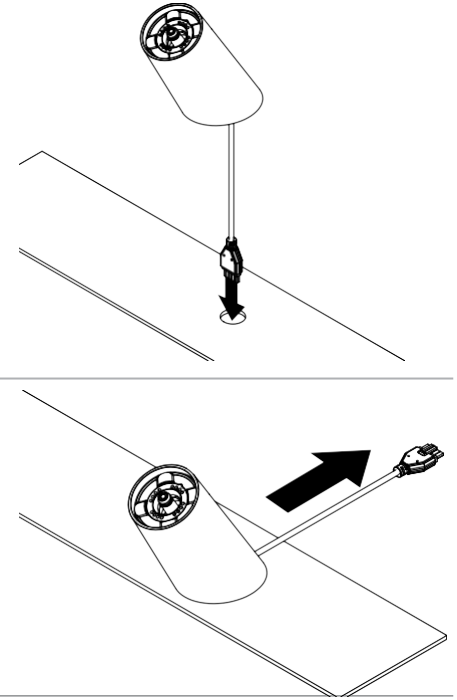

- 4a Optional:**
If using a DIB or smart hub:
Plug the corresponding data cable into the port in the bottom of the stand.

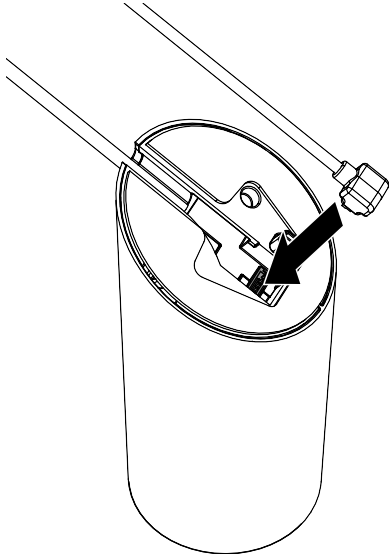

- 4b If using a DIB or smart hub:**
Plug the cable into the DIB box or smart hub.

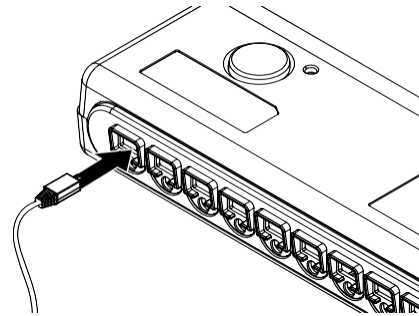

OR

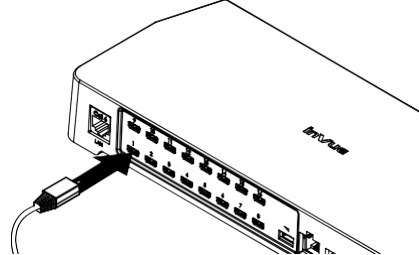

- 5a Optional:**
If using the stud mount kit, thread the stud into the bottom of the stand.

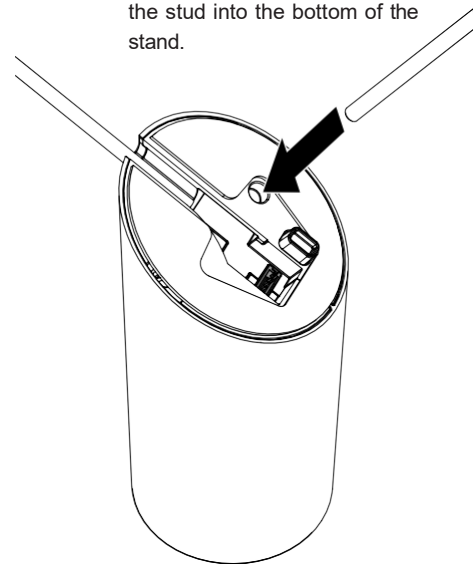

- 5b Optional:**
If using the stud mount kit, thread the stud into the bottom of the stand.

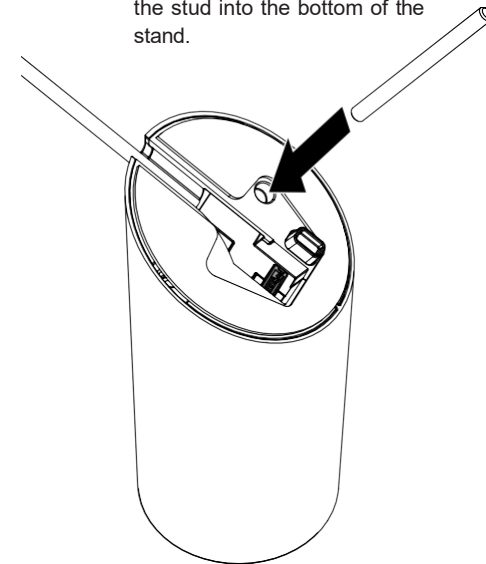

Note: If using the lock down feature on the stand, the use of the stud mount kit is recommended.

- 6 Consider where the stand will be mounted. **Be sure the plunger on the bottom will press against the fixture surface.**

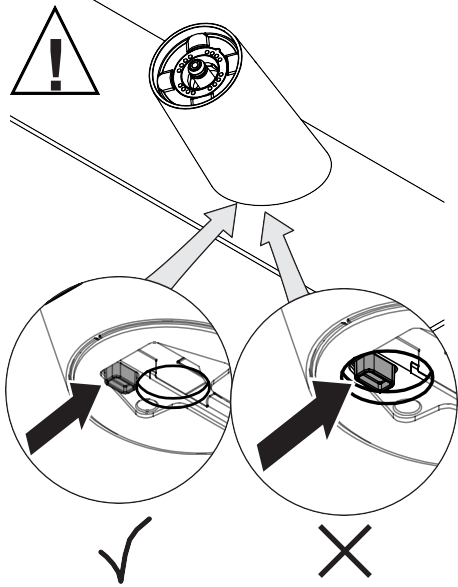

- 7 Remove clear film from adhesive.

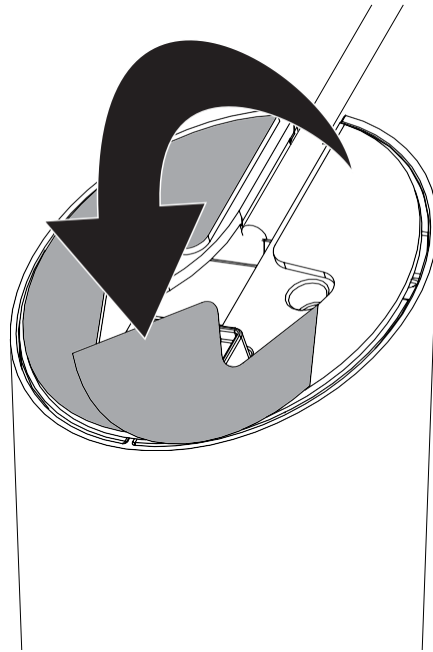

- 8 Press stand onto surface for at least 10 seconds.

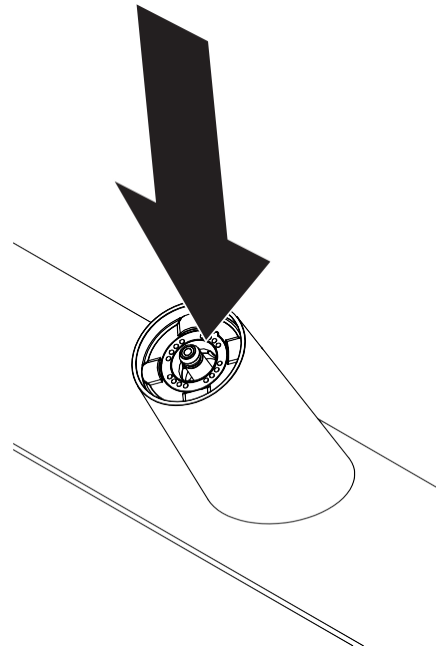

- 9 **Optional:** If using a stud mount kit, attach the plastic washer and wing nut to the stud below the fixture and tighten by hand to secure the stand to the fixture.

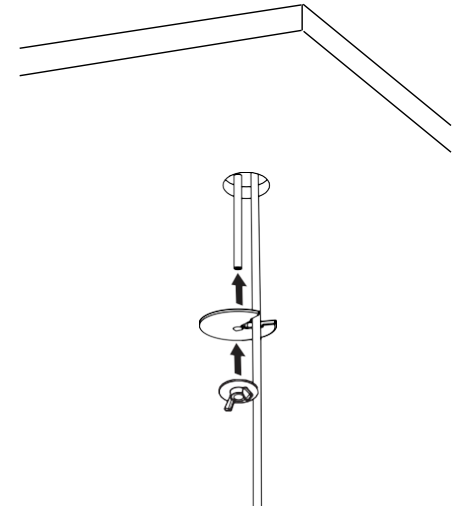

- 10 **Be sure power is applied in this order.** Plug the power cable into the power supply. Plug the power supply into the wall. The stand will chirp.

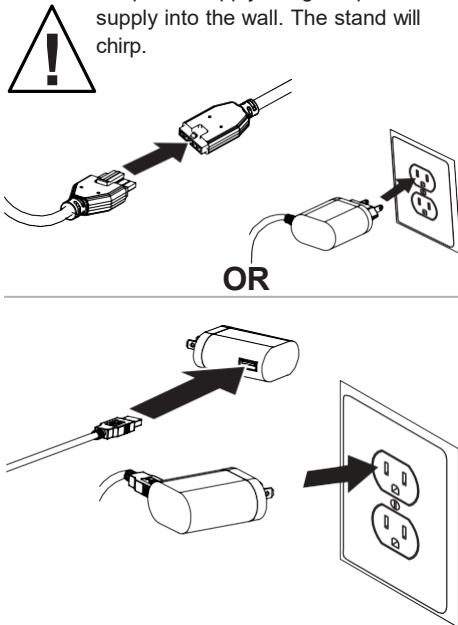

- 11 **Sensor Installation:** Wipe the back of device with the provided alcohol pad. **Let it dry completely.**

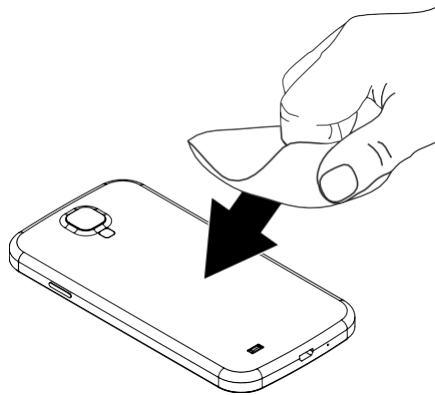

Note: Some devices may require the usage of a polish kit (ADH2300 or ADH2313) to promote the adhesion of an LSE plate or adhesive.

- 12 Plug the power connector into the sensor.

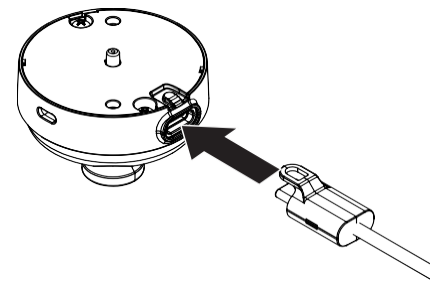

- 13a **Optional:** If bracket arms will be used in this installation, please see those instructions now.

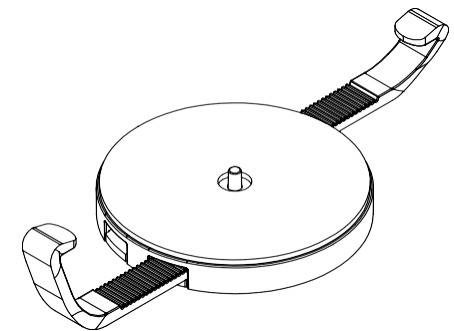

- 13b Important:**
If using an LSE plate, make sure that the plunger on the plate sits in the cut-out on the LSE plate.

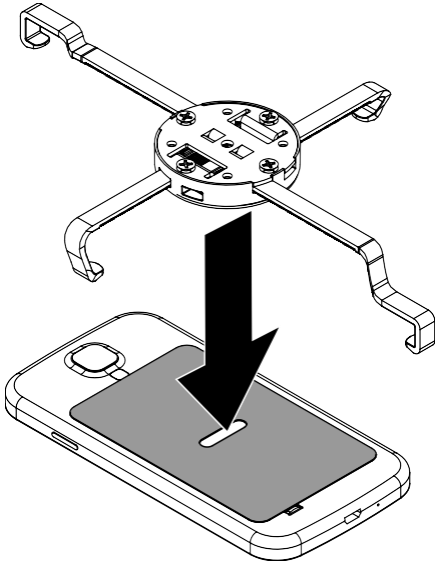

- 14** Wipe the flat surface of the sensor with the provided alcohol pad. **Let it dry completely.**

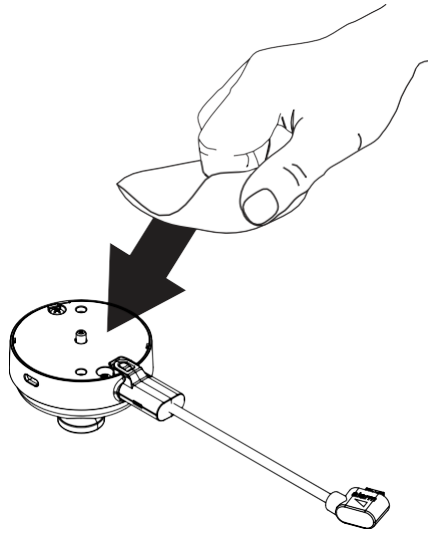

- 15** Remove the adhesive from the paper backing and place it onto the sensor. Apply pressure for at least 10 seconds.

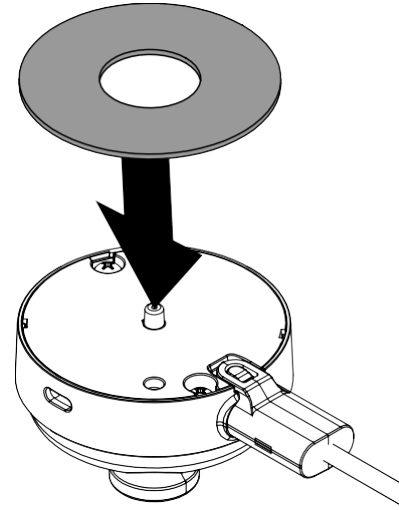

- 16** Plug the power connector into the device.

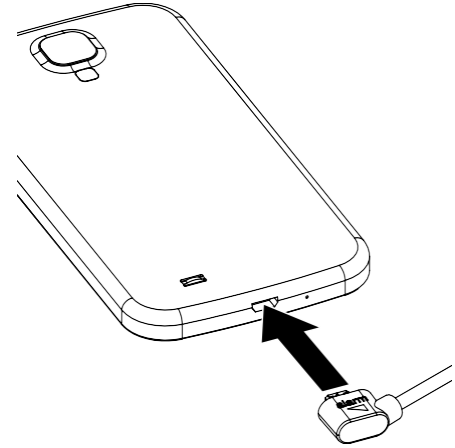

- 17** Peel the clear film from the adhesive on the sensor.

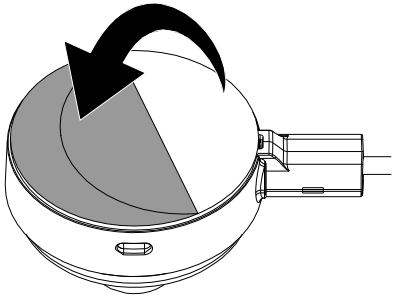

- 18a** Center the sensor on the back of the device and apply pressure for at least 10 seconds.

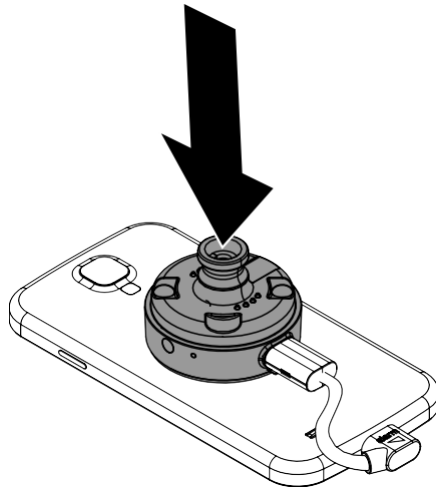

- 18b Important:**
If an LSE plate was used, make sure that the plunger on the sensor sits in the cut-out on the LSE plate.

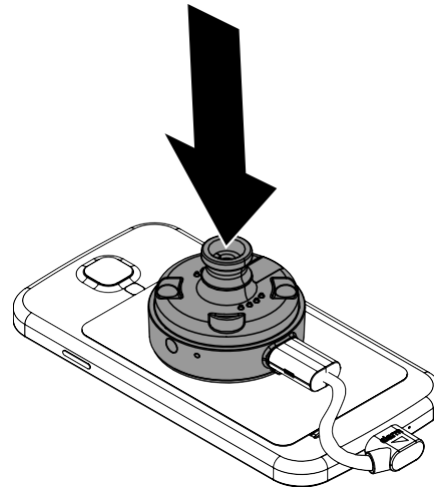

- 19 Attaching the Sensor to the Stand:**
Pull the sensor cable from the stand.

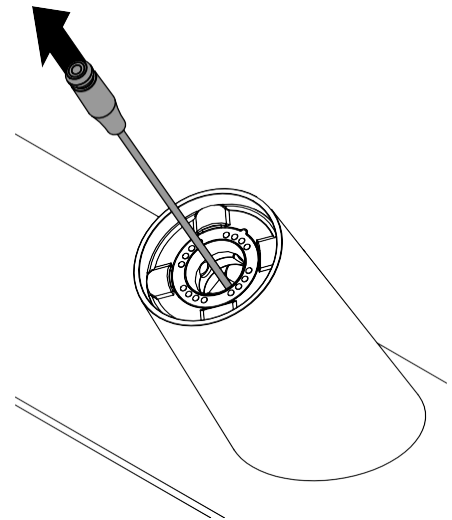

- 20 Plug the sensor cable into the sensor. The sensor will click when the cable is inserted properly.

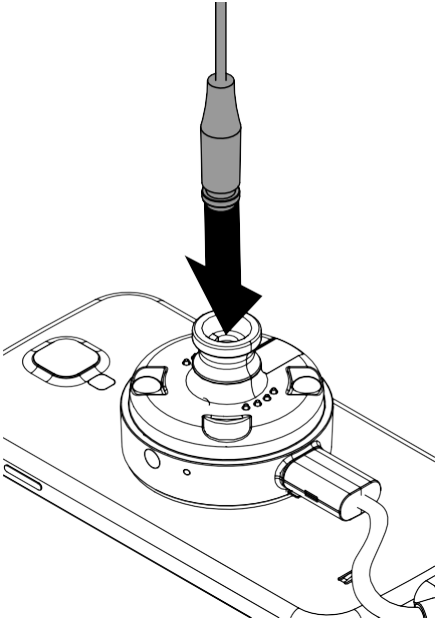

- 21 Place the sensor and device onto the stand.

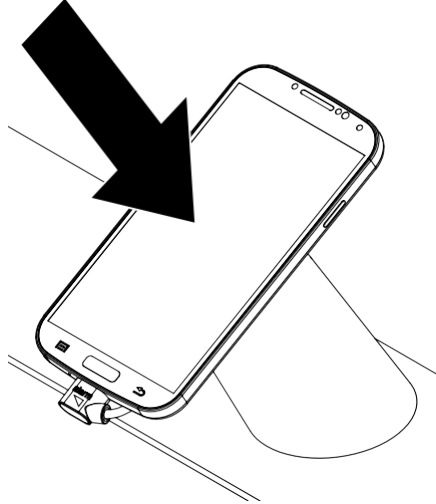

- 22 Place a charged and coded IR key against the lens on the side of the sensor. Press the button on the key to transfer the code to the stand and sensor. The stand will chirp to confirm.

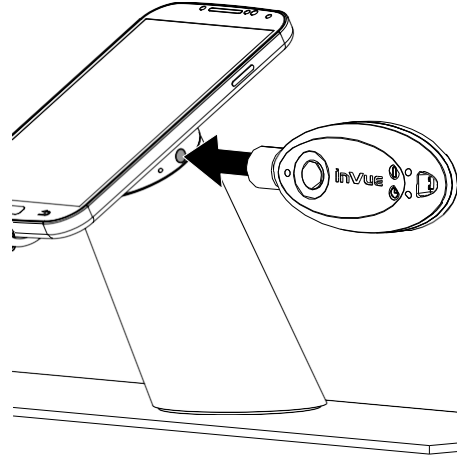

- 23 **Optional:** To secure the sensor to the stand and prevent the device from being lifted. Insert the magnet key (DBG400 or DBG406) into the depression on the back of the stand and turn it 1/4 turn clockwise. Turn the key counterclockwise to unlock the sensor.

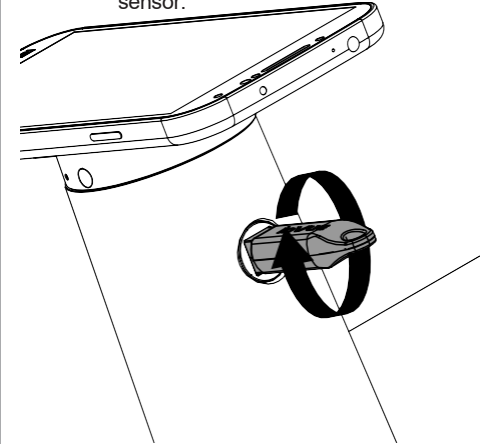

- 24 **Optional:** If present, plug a power/alarm auxiliary sensor into the back of the stand. The stand will chirp.

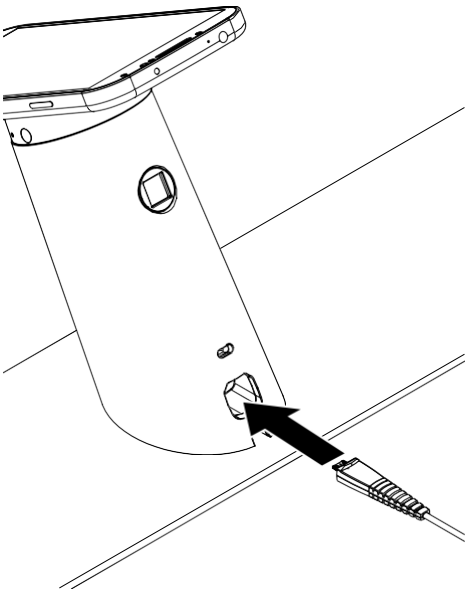

- 1 **Removal:** Deactivate the stand by placing a charged and coded IR key against the IR lens on the side of the sensor and pressing the button. The stand will chirp to confirm.

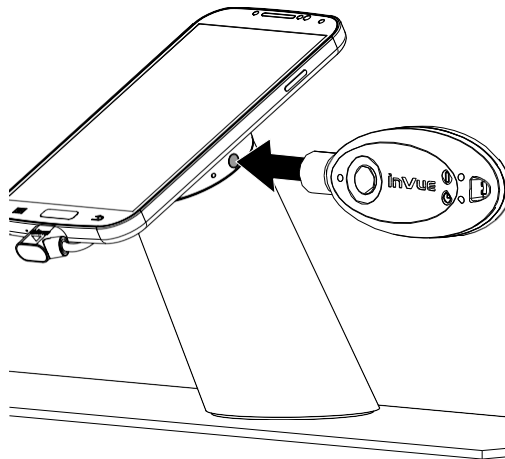

- 2 Unplug the power supply from the wall and disconnect the power supply from the stand's power cable.

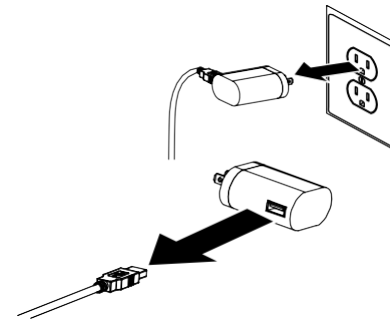
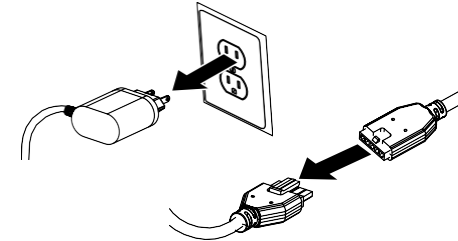

- 3 Remove the sensor and device from the stand. Place the magnet key (DBG400 or DBG406) into the depression on the sensor and push it inward to release the sensor cable. Pull the cable free.

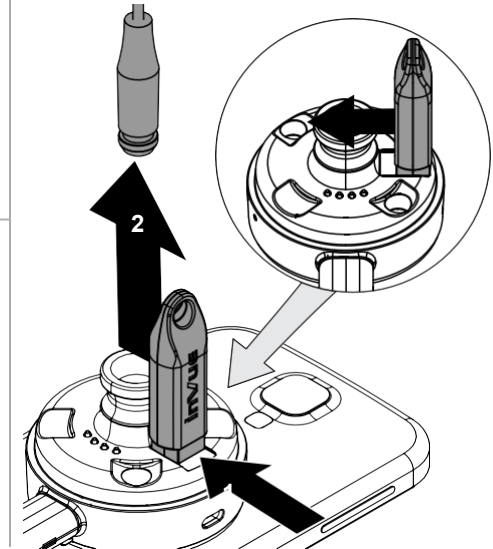

4

Use the scraper removal attachment (DNTX93) to break the adhesive bond between the stand and the surface.

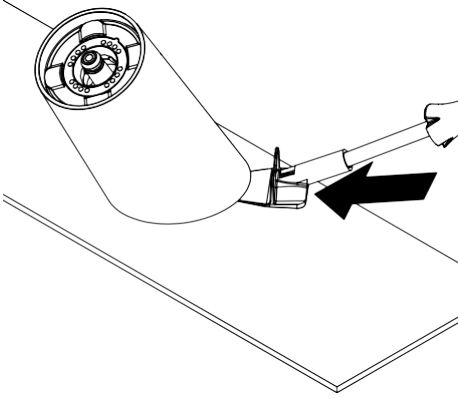

5

To remove sensor from device:

1. Unplug alarm/power connector from device.
2. Use the scraper removal attachment (DNTX93) to break the adhesive bond between the sensor and the device.

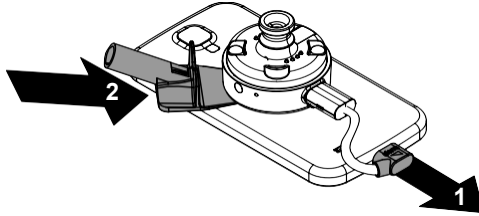

SD0546 Rev5 06/17/19

inVUE

www.invue.com

NA / LATAM // 704.752.6513 • 888.55.INVUE

EMEA // +31.23.8900150

APAC // +852.3127.6811