

## One55 & One65 Re-Merchandising Guide

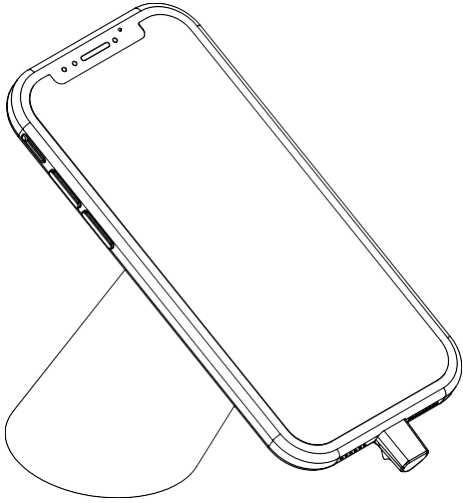

- 1 Deactivate the stand by placing a charged and coded IR key against the IR lens on the side of the sensor and pressing the button. The stand will chirp to confirm.

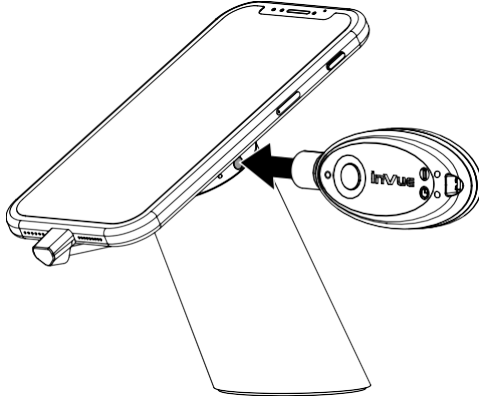

- 2 Remove the sensor and device from the stand. Place the magnet key (DBG400) into the depression on the sensor and push it inward to release the sensor cable. Pull the cable free.

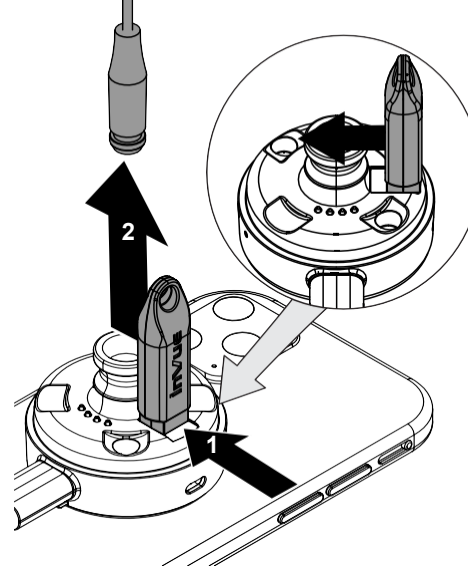

- 3 Unplug the power connector from the device.

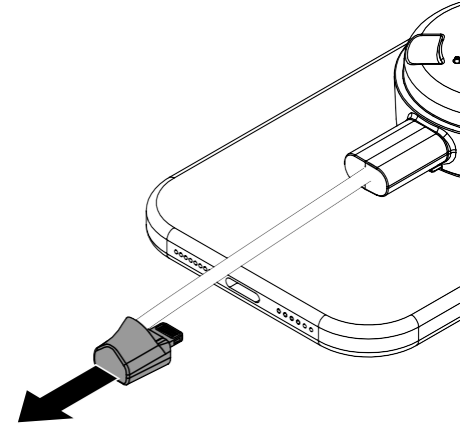

- 4 Insert the scraper removal tool (DNTX93) between the sensor and device. Carefully work the scraper tool back and forth to break the adhesive bond between the sensor and the device.

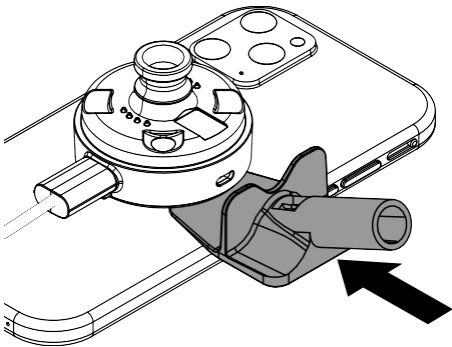

- 5 If the sensor will be reused, peel the old adhesive from the sensor.

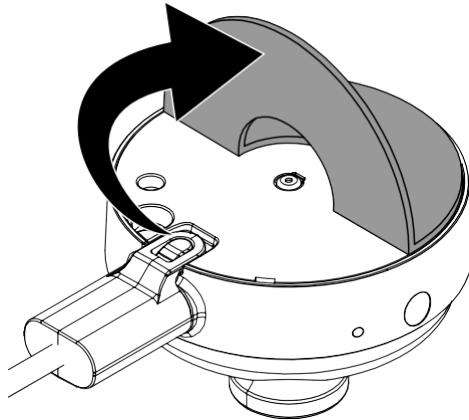

- 6 Use an alcohol wipe to clean any adhesive residue from the sensor. Allow it to dry completely.

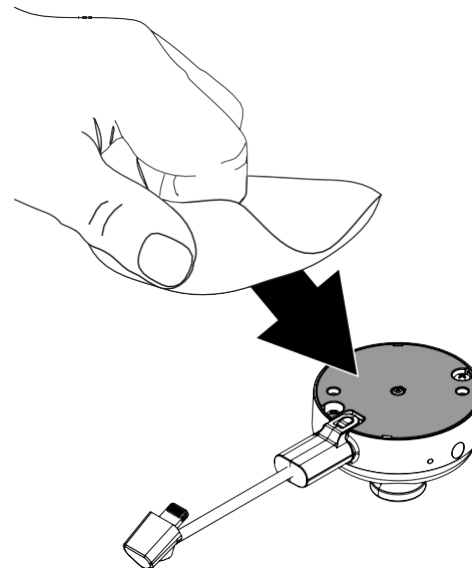

- 7 Remove one of the replacement adhesives (ADH2180) from its backing and align it with the flat surface of the sensor. Smooth it into place for at least 10 seconds.  
**Note:** The sensor is now ready to be reinstalled. Consult the installation guide for more information.

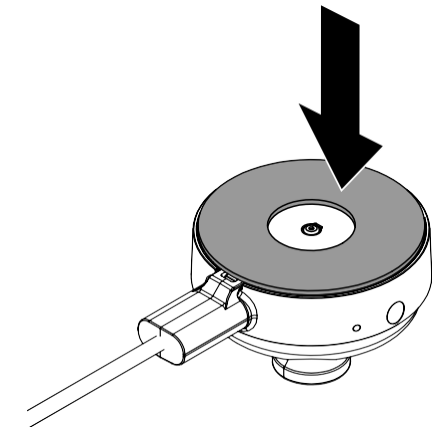

- 8 If the device will be installed on a different position, use an alcohol wipe to clean any adhesive residue from the device. Allow it to dry completely.

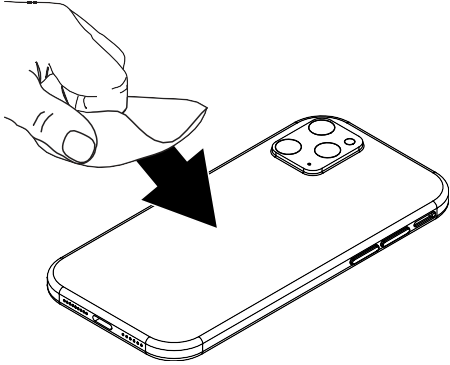

**Note:** Some devices may require the usage of a polish kit (ADH2300 or ADH2313) to promote the adhesion of an LSE plate or adhesive.

- 9 If removing the stand, unplug the power supply from the power source and unplug the stand from the power supply.

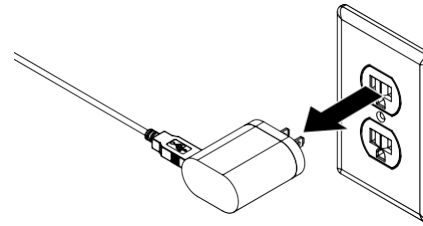
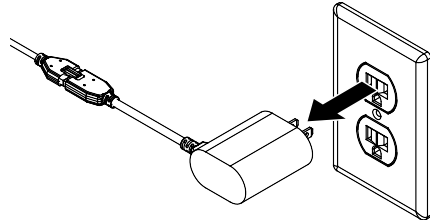

OR

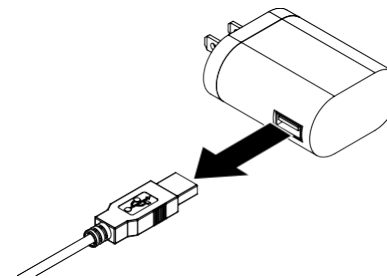
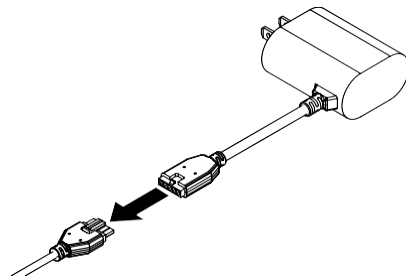

- 10 Use the scraper removal tool (DNTX93) to break the adhesive bond between the stand and the fixture surface.

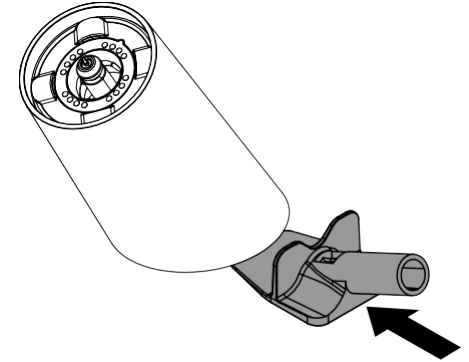

- 11 If the S960 stand will be reinstalled, peel the old adhesive from the stand.

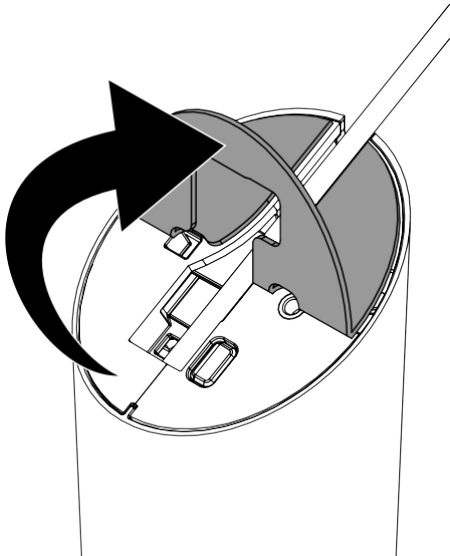

- 12 Use an alcohol wipe to clean any adhesive residue from the bottom of the stand. Allow it to dry completely.

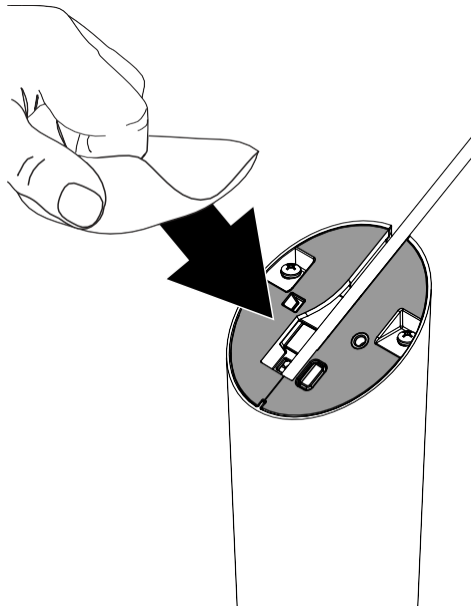

- 13 Remove one of the replacement adhesives (ADH2181) from its backing and align it with the bottom of the stand. Smooth it into place for at least 10 seconds.
- Note:** The stand is now ready to be reinstalled. Consult the installation guide for more information.

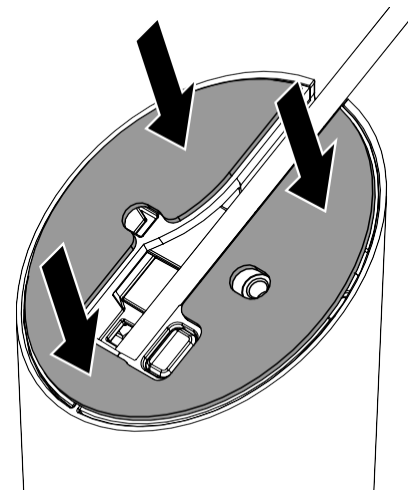

Rev0 08/18/22

**invue**

[www.invue.com](http://www.invue.com)

NA / LATAM // 704.752.6513 • 888.55.INVUE

EMEA // +31.23.8900150

APAC // +852.3127.6811

© 2022 InVue Security Products Inc. All rights reserved.  
InVue is a registered trademark of InVue Security Products.